



About the Fisher Technology Development Center

Marshalltown, Iowa, USA, is the epicenter of flow control technology.

The newly constructed Fisher Technology Development Center is the fourth generation flow lab that has been in Marshalltown. The first lab was built in the 1930s.

The new center will continue Emerson's role as a leader in major research and development for process control. It will more than quadruple both air and water flow rate capabilities, allowing Emerson to flow test some of the largest control valves being produced.

The Fisher Technology Development Center includes facilities for:

- Flow verification testing up to 36 inch pipe size
- Flow sciences research and development
- Simulation and analysis of flow geometries
- Piping vibration, flow and vent noise
- Instrument and software development
- Dynamic performance
- Materials
- High temperature air
- Test pressures up to 3500 psig using water or air
- Cycle life
- Experimental stress analysis
- Vibration and seismic testing
- Prototype manufacture
- Leak detection
- Customer demonstrations and witness testing

Lodging

A block of rooms have been reserved at the following location. When reserving a room, please specify that you are a guest of the Fisher Control Valve Procurement Seminar.

- Regency Inn, 641-752-6321

Directions

Emerson Process Management
 Fisher Technology Development Center
 301 South 1st Avenue
 Marshalltown, Iowa 50158

The approximate distance from the Des Moines airport to Marshalltown is 60 miles.

Directions from Des Moines, Iowa, to Marshalltown:

- Exit airport and turn right onto Fleur Drive; go about 3 miles to Hwy 5 interchange
- Go East on Hwy 5 South (becomes Hwy 65) and proceed North on Hwy 65 to I-80
- Go East on I-80, watch for Highway 65 exit (left lane)
- Follow 65/330 to Marshalltown exit
- East on Hwy 30 to Hwy 14 exit
- North on Hwy 14 to lodging

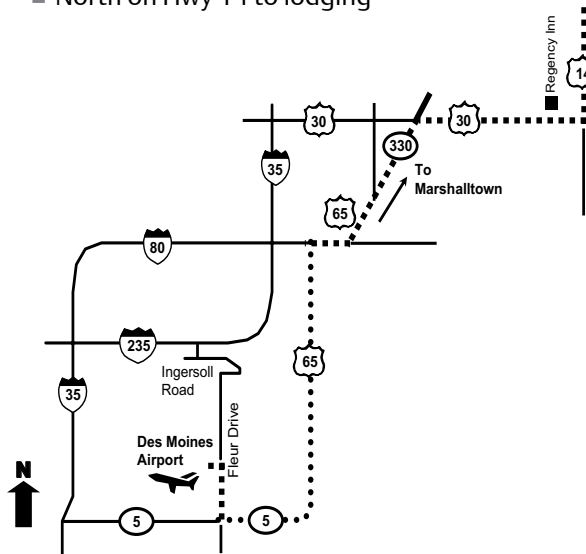

Control Valve Procurement Seminar

June 15 - 17, 2010

*New Fisher® Technology Development Center
 in Marshalltown, Iowa*



Control Valve Procurement Seminar

JUNE 15 - 17, 2010

You are invited to attend the Control Valve Procurement Seminar on June 15-17, 2010 at the Fisher® global headquarters in Marshalltown, Iowa.

The seminar will begin at 8 a.m. on Tuesday, June 15 and will conclude on Thursday, June 17. Lunch and dinner are included on Tuesday and Wednesday.

By attending the three-day Control Valve Procurement Seminar, you will learn about Emerson Process Management, the supplier of Fisher control valve solutions.

Fisher products and services provide industry-based solutions designed to reduce your total cost of ownership and improve your plant's operating profits. We are focused on developing cutting-edge technologies to improve your plant's availability and performance, while helping you reduce safety, health and environmental costs. We are also committed to utilizing processes to reduce costs in the project execution phase.

During the seminar you will have the opportunity to tour the new Fisher Technology Development Center where the most extensive applied research and testing in the industry is performed.

We sincerely hope that you can accept our invitation. There is no fee to attend the Control Valve Procurement Seminar. Simply contact your Emerson sales representative to RSVP.



Doug Butler
Fisher Vice President Sales, North America

Agenda for Day 1: Tuesday, June 15

Fisher Main Office—Customer Conference Room

- 7:30 a.m. **Bus Departs Hotel for Fisher Main Office**
- 8:00 a.m. **Welcome/Introductions/Agenda Review**
Doug Butler - VP Sales North America
- 8:30 a.m. **Fisher Business Direction**
John Wilson - VP Global Industry Sales
- 9:00 a.m. **Design Process, Validation Testing and Research Overview**
Mark Riveland - Advance Technology Manager
Galen Wilke - VP Sliding-Stem Valves
- 9:45 a.m. **Break**
- 10:15 a.m. **Control Valve Performance—The Key to Success**
Bill Flowers - Director Hydrocarbon Industry
- 11:00 a.m. **Control Valve Selection**
Karl Lanes - Director Chemical Process Industries
- 11:45 a.m. **Lunch**
- 12:45 p.m. **Special Products Capabilities Overview**
Ed Merwald - VP Engineered Products
- 1:15 p.m. **Digital Valve Instrumentation**
Danny Nelson - VP Instruments
- 2:00 p.m. **Break**
- 2:30 p.m. **New Fisher Technology Development Center Tour and Demonstrations**
Matt Estabrook - Sales Engineer
Clinton Anderson - Chemical Industry Manager
Charley DePenning - Global Test and Evaluation Mgr
- 4:30 p.m. **Adjourn—Bus Departs to Hotel**
- 6:00 p.m. **Dinner—Bus Departs Hotel for Rube's Steakhouse**
- 9:00 p.m. **Bus Departs to Hotel**

Day 2: Wednesday, June 16

Fisher Main Office—Customer Conference Room

- 7:30 a.m. **Bus Departs Hotel for Fisher Main Office**
- 8:00 a.m. **Day 1 Review / Day 2 Focus**
Doug Butler - VP Sales North America

Day 2 Continued

Fisher Main Office—Customer Conference Room

- 8:15 a.m. **Fisher Global Sales Organization**
Don Turbiville - President RS Stover
Mark Rezac - VP Sales
- 8:45 a.m. **Order Fulfillment and Project Management Process**
Jerry Major - VP Project Management
- 9:15 a.m. **Break**
- 9:45 a.m. **Procurement and Quality Processes**
Bob Stahlin - VP Global Supply
John Sankovitch - VP Global Operations
- 10:30 a.m. **Instrument and Valve Services Overview**
Tim Erman - Director Business Development IVS
- 11:00 a.m. **Value of Integrated Work Process**
Mark Henson - Director Power/OEM Industries
- 12:00 p.m. **Lunch**
- 1:00 p.m. **Relationship Building**
- 6:00 p.m. **Banquet—Regency Inn**
Dave Beckmann - Senior VP Marketing (Retired)
- 9:00 p.m. **Adjourn**

Day 3: Thursday, June 17

Fisher Governor Road Manufacturing Facility

- 7:30 a.m. **Bus Departs Hotel for Fisher Governor Road Manufacturing Facility**
- 8:00 a.m. **Day 2 Review / Day 3 Focus**
Doug Butler - VP Sales North America
- 8:15 a.m. **Overview of Manufacturing Processes**
Don Rowley - Governor Road Plant Manager
- 8:45 a.m. **Tour of Governor Road Mfg. Facility**
Lynn Jensen - Customer Service Manager
- 9:45 a.m. **Break—Bus Departs to Main Office**
- 10:15 a.m. **Value of Strategic Alliances**
Dick Livingston - Marquee Account Manager
Gayle Everitt - Chevron
- 11:15 a.m. **Seminar Key Takeaways**
Doug Butler - VP Sales North America
- 11:45 a.m. **Seminar Evaluation**
- 12:00 p.m. **Adjourn—Bus Departs to Hotel**